

The PowerSafe™ FTC-P product line ranges from 840Ah to 1810Ah and is specifically designed for the telecommunication industry. The PowerSafe FTC-P product line, utilizing proven flooded flat plate Calcium technology, is ideally suited for central office, cellular, and microwave applications, providing excellent long duration discharges.

RANGE SUMMARY

NEBS Certified

With the multi-directional design of the post, PowerSafe FTC-P cells are easily configurable in any orientation, with cells either perpendicular to the rack support rails to optimize footprint or parallel to enable easy maintenance while the system is online. The PowerSafe FTC-P product line also employs EnerSys' exclusive Slide-Lock™ post seal that allows for natural plate growth over time without degrading the seal and an innovative tongue and groove jar-to-cover seal to prevent leaks.

Features & Benefits

- Capacity range: 840Ah - 1810Ah
- Flat plate construction - lead calcium grid alloys. Well suited for long duration, float applications.
- Telecommunication industry WE list 508 standard 1680Ah battery (FTC-21P).
- Flame retardant (UL94-VO/L.O.I. 28%) container and cover.
- Slide-Lock™ Post Seal allows natural plate growth without degrading post seal.
- Innovative tongue and groove jar-to-cover seal.
- Configurable with plates either perpendicular (optimize footprint) or parallel (clean connectors while on line) to rack support rails.



General Specifications

TYPE*	NOM. Ah CAP	Nominal Dimensions						Weights - Volumes								
		Length**		Width		Height		Unpacked		Domestic Packed		Electrolyte Only / 1.215 S.G.				Short Circuit Current Amps
		in	mm	in	mm	in	mm	lbs	kg	lbs	kg	lbs	kg	gal	l	
FTC-11P	840	11.12	282	14.5	368	22.7	577	218	98.9	230	104.5	79.4	36.4	7.93	30.0	4532
FTC-21P	1680	11.12	282	14.5	368	22.7	577	303	137.4	315	142.9	70.1	31.8	6.92	26.2	9400
FTC-23P	1810	11.12	282	14.5	368	22.7	577	320	145.1	332	150.6	67.9	30.8	6.71	25.4	10340

* Suffix number indicates total plates per cell.
 ** 0.25" must be added between cells for spacing purposes when calculating total battery rack length.

SPECIFICATIONS

- PLATE THICKNESS:**
 Positive: 0.32 in/8.1 mm
 Negative: 0.24 in/6.1 mm
- PLATE DIMENSIONS:**
 Height Width
 Pos: 14.4 in/366 mm 12.1 in/307 mm
 Neg: 14.4 in/366 mm 12.1 in/307 mm
- SEDIMENT SPACE:**
 1.0 in/25.4 mm
- ELECTROLYTE OVER PLATES:**
 2.9 in/73.7 mm
- CONTAINER:**
 Container made from Flame Retardant PVC (UL94-VO/L.O.I. 28%)
- COVER:**
 Cover made from Flame Retardant PVC (UL94-VO/L.O.I. 28%)
- SEPARATORS:**
 Microporous rubber
- RETAINERS:**
 "Vitrex"- glass fiber
- POST TYPE:**
 Double Posts
- POST SEAL TYPE:**
 Slide-Lock™
- PLATE SUSPENSION TYPE:**
 Positive: Bridge hung
 Negative: Bottom supported
- ELECTROLYTE WITHDRAWAL TUBE:**
 One per cell
- VENT TYPE:**
 Flame Arrestor, Fused Alumina
- FLOAT VOLTAGE SETTING:**
 Acceptable min/max: 2.17/2.26Vpc
 Recommended: 2.25Vpc
- SPECIFIC GRAVITY:**
 1.215
- BOLT CONNECTORS:**
 Stainless steel, standard English measure, hex-head
- INTERCELL CONNECTORS:**
 Lead-plated copper

NOTE: All inter-cell connectors, inter-tier, inter-step, end-to-end inter-rack, back-to-back inter-rack cables, and terminal plates are included with every battery. Across-aisle inter-rack cables are not included

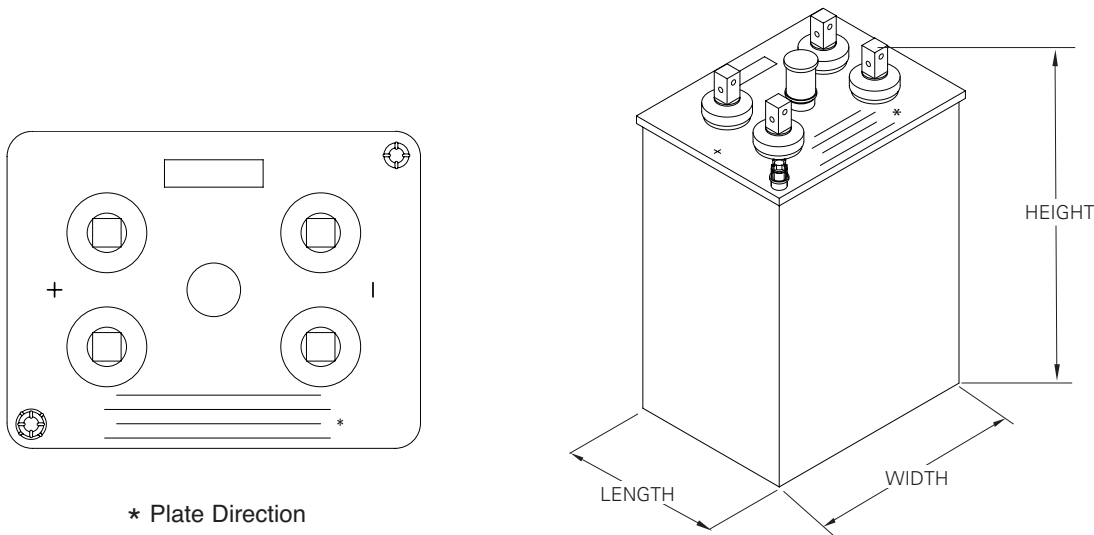

* Plate Direction



www.enersys.com

EnerSys
 P.O. Box 14145
 Reading, PA 19612-4145
 USA
 Tel: +1-610-208-1991
 +1-800-538-3627
 Fax: +1-610-372-8613

EnerSys EMEA
 Brussels, Belgium
 Tel: +32 (0)2 247 94 47

EnerSys Asia
 Guangdong, China
 Tel: +86-755-2689 3639

Distributed by:

Printed in the U.S.A
 © 2006 EnerSys. All rights reserved.
 Trademarks and logos are the property of EnerSys and its affiliates unless otherwise noted.