

LONG DURATION SERIES



TEL6-180 VALVE REGULATED LEAD ACID BATTERY FOR COMMUNICATIONS STANDBY POWER APPLICATIONS

FEATURES

- Flame-arresting one-way pressure-relief vent for safety and long life.
- Thermally welded case-to-cover bond to ensure a leak-proof seal.
- Flame-retardant polypropylene case and cover compliant with UL94 V-0 with an Oxygen Limiting Index of greater than 28.
- Absorbent Glass Mat (AGM) technology for efficient gas recombination 99% plus.
- Thick positive plate design for maximum service float life – 10 year design life.
- Complies with UL1778, 924, 1989 and 94 V-0.
- UL-recognized component.
- Can be used in any orientation. Upright, side or end mounting recommended.
- Low-profile terminals with threaded copper alloy inserts for reduced height, reduced maintenance and increased safety.
- Multicell design for ease of installation and maintenance.
- Not restricted for air transport – Complies with IATA/ICAO Special Provision A67
- Not restricted for surface transport – classified as non-hazardous material as related to DOT-CFR Title 49 parts 171-189
- Not restricted for water transport – classified as non-hazardous material per IMDG Amendment 27.

6 Volts – 176 Ampere Hour Capacity @ 8 Hour Rate

Ampere Hour Capacity to 1.75 Volts per Cell @ 77°F (25°C)

Discharge in Hours	1.00	2.00	3.00	4.00	5.00	6.00	7.00	8.00	10.00	12.00	20.00	24.00	72.00	100.00
Amp-Hr Capacity	123	139	150	157	162	168	172	176	182	187	200	201	207	208

C&D Technologies, Inc.
DYNASTY Division
900 East Keefe Avenue
Milwaukee, WI 53212
Phone: 800-396-2789
Fax: 414-961-6506



TEL6-180

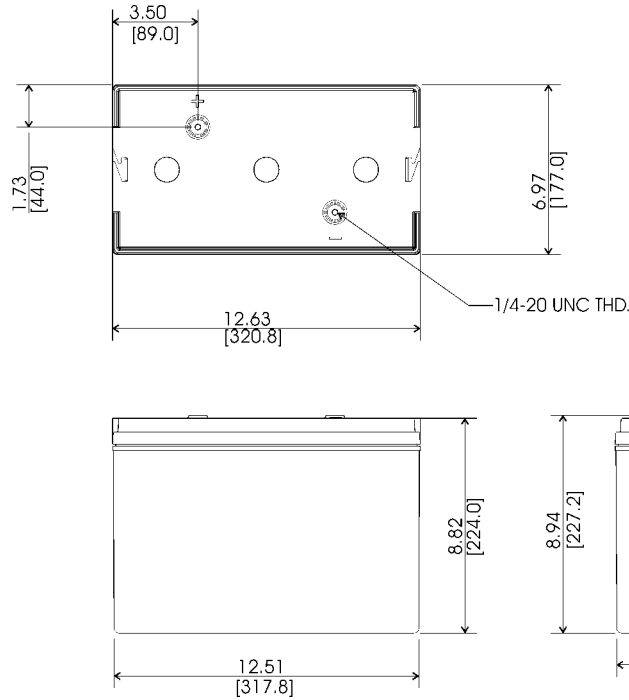

TEL6-180 – Specifications

*All dimensions in inches and (millimeters). All dimensions are for reference only. Contact a C&D Representative for complete dimensional information.

Cells Per Unit	Voltage Per Unit	Weight	Electrolyte	Maximum Discharge Current	Short Circuit Current	Ohms Imped. 60 Hz (Ω)
3	6.42	72 lbs. 33 kg	Absorbed H ₂ SO ₄ SG = 1.300	800 Amps	4350 Amps @ 0.1 sec.	0.0015 Ohms

Capacity	176 Ah @ 8 hour rate to 1.75 volts per cell @ 77° F (25° C) 171 Ah @ 10 hour rate to 1.80 volts per cell @ 20° C (68° F)
Operating Temperature Range	Discharge; -40° F (-40° C) to +160° F (71° C), Charge; -10° F (-23° C) to +140° F (60° C) <small>(with temperature compensation)</small>
Nominal Operating Temperature Range	+74° F (23° C) to +80° F (27° C)
Float Charging Voltage	6.75 to 6.9 VDC/unit Average @ 77° F (25° C)
Recommended Maximum Charging Current Limit	C/5 amperes (40 amps @ 100% depth of discharge)
Maximum AC Ripple (Charger)	0.5% RMS or 1.5% P-P of float charge voltage recommended for best results. Maximum voltage allowed = 4% P-P Maximum current allowed = 10 amperes RMS (C/20)
Self Discharge	Dynasty Telecom batteries may be stored for up to 6 months at 77° F (25° C) and then a refreshing charge is required. For higher temperatures the time interval will be shorter.
Accessories	Inter unit connectors, racks and cabinet systems are available.
Terminal	Threaded copper alloy insert terminal to accept 1/4-20 UNC bolt.
Terminal Hardware Initial Torque	110 in.-lbs. (12.4 N-m).

Constant Current Discharge Ratings – Amperes @ 77° F (25° C)

End Point Volts/Cell	Operating Time to End Point Voltage (in hours)													
	1.00	2.00	3.00	4.00	5.00	6.00	7.00	8.00	10.00	12.00	20.00	24.00	72.00	100.00
1.75	123	69.5	50.0	39.2	32.4	28.0	24.6	22.0	18.2	15.6	10.0	8.38	2.87	2.08
1.80	120	68.0	48.3	38.0	31.6	27.2	23.8	21.3	17.6	15.2	9.8	8.21	2.83	2.05
1.85	110	62.7	45.5	36.0	30.0	25.8	22.7	20.3	16.9	14.5	9.3	7.84	2.73	1.98
1.90	94	57.7	42.0	33.5	27.9	24.0	21.1	19.0	15.8	13.5	8.7	7.31	2.51	1.82

Note: Batteries to be mounted with 0.5 in. spacing minimum and free air ventilation. Specifications are subject to change without notification.